

General Description

2-Way Poppet Valves.
 For additional information see Technical Tips on pages SV2-SV6.

Features

- Replaceable, one piece encapsulated coils with minimal amperage draw
- Various coil terminations and voltages
- Various manual override options
- All external parts zinc plated
- New 250 Bar (3600 PSI) rating

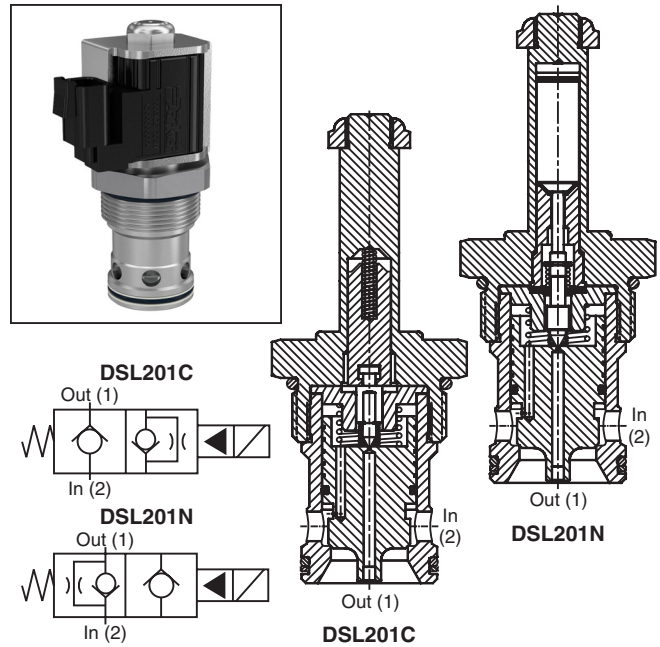

Specifications

Rated Flow	260 LPM (70 GPM)									
Maximum Inlet Pressure	250 Bar (3600 PSI)									
Leakage at 150 SSU (32 cSt)	5 drops/min. (.33 cc/min.)									
Minimum Operating Voltage	85% of rated voltage at 20°C (72°F).									
Response Time	<table border="1"> <thead> <tr> <th></th> <th>Energized</th> <th>De-Energized</th> </tr> </thead> <tbody> <tr> <td>C, CR</td> <td>350 ms</td> <td>160 ms</td> </tr> <tr> <td>N, NR</td> <td>300 ms</td> <td>45 ms</td> </tr> </tbody> </table>		Energized	De-Energized	C, CR	350 ms	160 ms	N, NR	300 ms	45 ms
	Energized	De-Energized								
C, CR	350 ms	160 ms								
N, NR	300 ms	45 ms								
Cartridge Material	All parts steel. All operating parts hardened steel.									
Operating Temp. Range/Seals	-34°C to +121°C (Nitrile) (-30°F to +250°F) -26°C to +204°C (Fluorocarbon) (-15°F to +400°F)									
Fluid Compatibility/Viscosity	Mineral-based or synthetic with lubricating properties at viscosities of 45 to 2000 SSU (6 to 420 cSt)									
Filtration	ISO 4406 18/16/13, SAE Class 4									
Approx. Weight	.34 kg (.75 lbs.)									
Cavity	C20-2 (See BC Section for more details)									

Performance Curve

Pressure Drop vs. Flow (Through cartridge only)

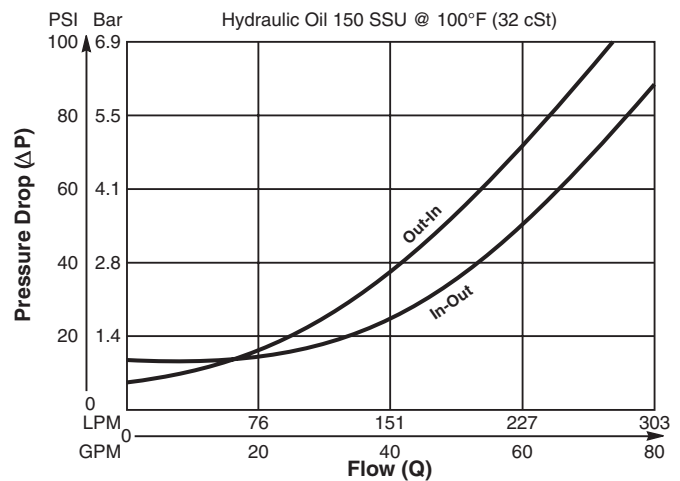

CV
Check Valves
SH
Shuttle Valves
LM
Load/Motor Controls
FC
Flow Controls
PC
Pressure Controls
LE
Logic Elements
DC
Directional Controls
SV
Solenoid Valves
PV
Proportional Valves
CE
Coils & Electronics
BC
Bodies & Cavities
TD
Technical Data

Dimensions Millimeters (Inches)

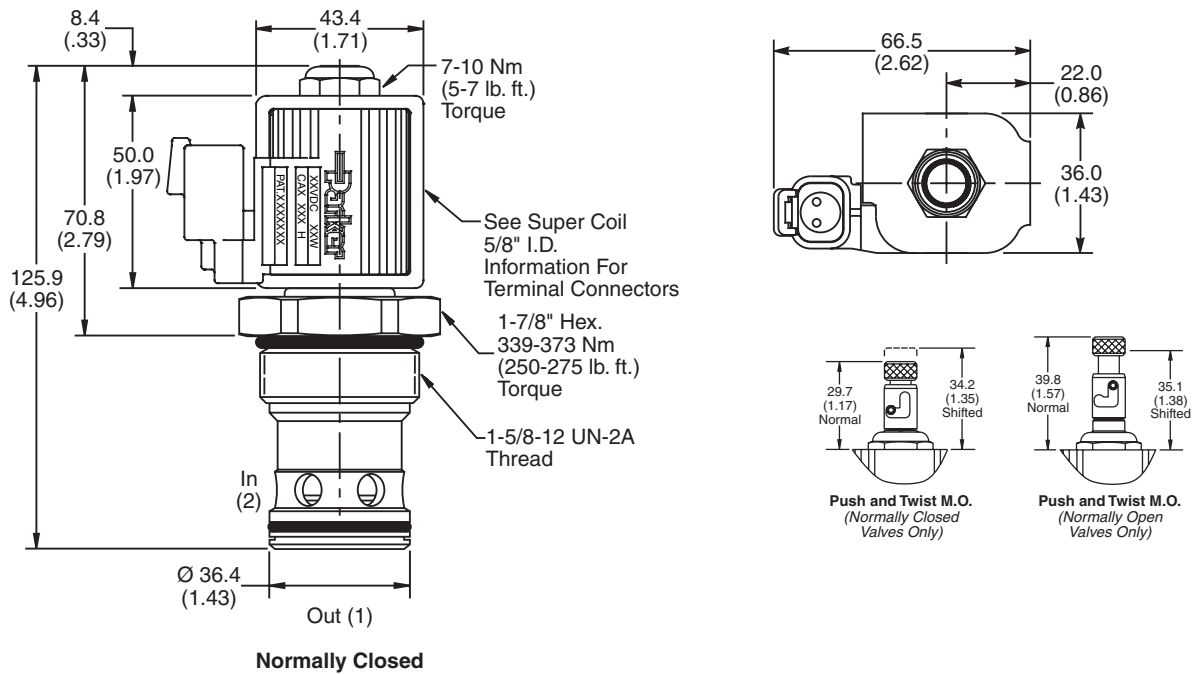

Ordering Information

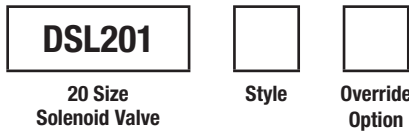

Highlighted represents preferred options that offer the shortest lead times. Other options may be available, but at extended lead times.

Coil(s) sold separately. Please see section CE of this catalog, 5/8" Super-Coil (CA series), for ordering information.

*Order Bodies Separately
 See section BC*

Code / Style	Diagram
C Normally Closed Metered reverse flow	
CR Normally Closed Free reverse flow	
N Normally Open Metered reverse flow	
NR Normally Open Free reverse flow	

Code	Override Options
Omit	None
T	Push & Twist (N.C. & N.O.)



Code	Seals
Omit	Nitrile

Code	Port Size / Body Material
20T	SAE-20 / Steel (5000 PSI)

Kit	Part Number
Nitrile Seal	SK20-2
Fluorocarbon Seal	SK20-2V



CV
Check Valves

SH
Shuttle Valves

LM
Load/Motor Controls

FC
Flow Controls

PC
Pressure Controls

LE
Logic Elements

DC
Directional Controls

SV
Solenoid Valves

PV
Proportional Valves

CE
Coils & Electronics

BC
Bodies & Cavities

TD
Technical Data